

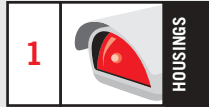

HEB32K



HEB32K + WB0V



- Indoor/Outdoor installations
- Extruded aluminium body, epoxy painted
- Hinged, removable body
- Double mounting option: regular or feed-through brackets
- Weatherproof Standard IP66 with WBM bracket and cable-glands

New design, weatherproof housing for outdoor installations. Its dimensions make it suitable for several 1/2", 1/3" and 1/4" CCD cameras equipped with a wide range of lenses. Made of extruded and die-cast aluminium, it is provided with an innovative opening system which allows access to the housings's interior; the body and the sunshield slide forward and hang in place, while the unit remains fixed allowing access to the camera from all angles. This can be done from either sides for a rapid installation and easy adjustment.

Its weatherproof features are ensured by the thermo-shaped EPDM-rubber gaskets and 2 PG9 and 1 PG11 cable glands with their specific gaskets. The rear mounting bracket offers vandal-proof protection due to the internal cable channel for concealed power and video cables.

A wide range of accessories is available, including sunshield, normal and fan-assisted heater, blower kit and camera power supply. The accessories are supplied factory installed or as a simple upgrade kit.

MODELS					
	Length mm / in	Sunshield	Heater 115/230VAC	Heater 12VDC/24VAC	Heater 24VAC fan-assisted
HEB26D0A000B	260 / 10				
HEB26K0A000B	260 / 10	•			
HEB26K1A000B	260 / 10	•	•		
HEB26K2A000B	260 / 10	•		•	
HEB32D0A000B	320 / 12.5				
HEB32K0A000B	320 / 12.5	•			
HEB32K1A000B	320 / 12.5	•	•		
HEB32K2A000B	320 / 12.5	•		•	
HEB32K2A015B	320 / 12.5	•			•

* Heater fed only in 230VAC or 24VAC

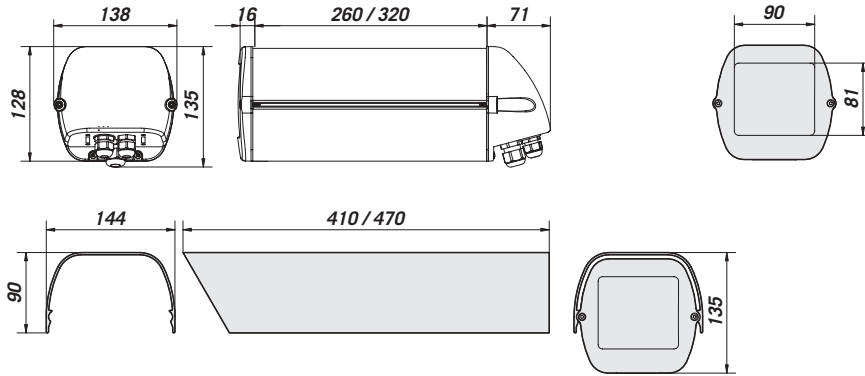

The values are in millimeters.

TECHNICAL DATA

GENERAL

- Die-cast aluminium back and front cover plates
- Extruded aluminium body and external slide
- Epoxy polyester powder painted colour RAL9002
- Stainless steel external screws
- Supplied with: instruction manual, desiccant bag, accessories for camera and lens mounting

MECHANICAL

- 3 cable-glands: 2xPG9 and 1xPG11
- Internal usable dimensions (WxH): 90x85 mm (3.54x3.34 in)
- Glass window (WxH): 90x81 mm (3.54x3.18 in)

Usable length mm (in):

Housing:

HEB26	260 mm (10.23 in)
HEB32	320 mm (12.59 in)

Housing with heater:

HEB26	190 mm (7.48 in)
HEB32	250 mm (9.84 in)

Housing with heater and/or camera power supply:

HEB26	190 mm (7.48 in)
HEB32	250 mm (9.84 in)

Housing with heater and/or blower:

HEB26	190 mm (7.48 in)
HEB32	250 mm (9.84 in)

ELECTRICAL

Heater, Ton 15°C+/-3°C (59°F) Toff 22°C +/-3°C (71°F):

OHEH09B	IN 12VDC/24VAC, consumption 20W
OHEH10B	IN 115/230VAC, consumption 40W

Blower with air filter and thermostat, Ton 35°C +/-3° (95°F) Toff 20°C +/-3° (68°F):

OHEBVF1	IN 12VDC, consumption 4 W (max)
OHEBVF2	IN 24VAC, consumption 4 W (max)
OHEBVF3	IN 230VAC, consumption 4 W (max)

Camera power supply:

OHEPS01B	IN 100-240VAC, 50/60Hz - OUT 12VDC, 1A max
OHEPS02B	IN 230VAC, 50Hz - OUT 24VAC, 400mA max

ACCESSORIES

OHEBS26	Sunshield 260 mm
OHEBS32	Sunshield 320 mm
OHEH09	Heater IN 12VDC/24VAC

OHEH10	Heater IN 115/230VAC
OHEBVF1	Blower with thermostat and air filter IN 12VDC
OHEBVF2	Blower with thermostat and air filter IN 24VAC
OHEBVF3	Blower with thermostat and air filter IN 230VAC
OHEPS01B	Camera power supply IN 230VAC - OUT 12VDC
OHEPS02B	Camera power supply IN 230VAC - OUT 24VAC
OHEGBB	Junction box

RELATED PRODUCTS

Mounts:

WBJ	Wall mount, installation with cable glands
WFCW	Column mount, installation with cable glands
WCM3	Ceiling mount, installation with cable glands
WCM5	Ceiling mount, installation with cable glands
WBOV	Wall mount with integral cable management
WBOV3	Wall mount with integral cable management, support plate and integrated junction box
WCM4	Ceiling mount with integral cable management

P&T:

PTH300 series	P&T, 50/60Hz
PTH900 series	P&T, 50/60Hz

ENVIRONMENTAL

- Indoor/outdoor
- Operating temperature with heater: -20°C up to + 50°C (-4°F up to 122°F)
- Resistant to the salt-air fog until 1000 hours (according to ISO9227)

COMPLIANCE TO

- CE according to EN 61000-6-3, EN 60065, EN 50082-1
- IP66 according to EN 60529 (with cable glands)
- IP54 according to EN 60529 (without cable glands)

SPARE PARTS LIST

OHBCFA04	Front cover, gaskets and screws
OHEBMAN	Cable glands, gaskets and screws
DOTHE01	Spacers for camera and lens



Unit Weight (kg / lb):
HEB26K: 2,85 / 6.28
HEB32K: 3,2 / 7.05

Package Weight (kg / lb):
HEB26K: 3,1 / 6.83
HEB32K: 3,45 / 7.6

Package Dimensions (cm / in):
HEB26K: 16x15x43
HEB32K: 16,5x15,5x49

Master Carton (units):
HEB26K: 10
HEB32K: 10