

Experience delivers aesthetically pleasing housing units.

- Perfect for**
- Airports • Banks
 - Hotels • Hospitals
 - Lobbies • Offices
 - Retail stores • Schools
 - Restaurants • Waiting areas
 - Government facilities

Videolarm features a variety of Indoor Housing styles, available in plastic or metal construction. Choose your own camera and lens for these aesthetically pleasing, well-designed housing units.

IPCH8

<ul style="list-style-type: none"> • High-impact polycarbonate housing and window • Mount easily converts from ceiling to wall configuration • Flip open top for easy access • Adjustable camera sled • Includes right angle BNC • Dimensions: Housing Length - 9.3" with mount - 11.1" Housing Width - 4.7" Housing Height - 3.9" with mount - 7.7" • Available as Videokit™ model

RC200

<ul style="list-style-type: none"> • Replaces standard 2x2 ceiling tile • Manually adjustable for 360° viewing • Lightweight, requires no special ceiling support • Viewing window sonically welded to snap-in mount • Metal back box available • Dimensions: Housing Width - 24" Housing Height - 6.25" • Available as Videokit™ model

ACE20

<ul style="list-style-type: none"> • Ceiling mount wedge housing • High-impact polycarbonate housing and window • Easy installation to any type ceiling • Molded-in hinge for easy access from below • Tamper resistant fasteners • Fully adjustable camera bracket • Includes right angle BNC • Dimensions: Housing Length - 10.25" Housing Width - 5.75" Housing Height - 4.5" • Available as Videokit™ model

ACN90

<ul style="list-style-type: none"> • Compact corner mount • Polycarbonate body and window • Tamper resistant fasteners • Cable access from back • Includes adjustable camera bracket • Includes right angle BNC • Dimensions: Housing Width - 5.15" Housing Height - 7.16" Housing Depth - 7.14" • Available as Videokit™ model

CN90

<ul style="list-style-type: none"> • Standard corner mount • Rugged, high impact plastic body • Clear or tinted window (1 F stop light reduction) • Easy installation • Tamper resistant fasteners • Dimensions: Housing Width - 7.88" Housing Height - 11.88" Housing Depth - 10"

BH8W BlackHawk™

<ul style="list-style-type: none"> • High-impact polycarbonate housing and window • Includes DECO1 wall mount • Flip open top for easy access • Adjustable camera sled • Includes right angle BNC • Dimensions: Housing Length - 9.3" with mount: 13.375" Housing Width - 4.7" Housing Height - 3.9" with mount: 8.5"

AMS90



- Corner mount
- 14-gauge cold rolled steel body
- Barrel lock
- .220" thick clear polycarbonate window
- Includes Window Guard™ paint shield for vandal protection
- Off white powder coat finish
- Hinged lid for easy access
- **Dimensions:**
Housing Width - 5.5"
Housing Height - 8.25"
Housing Depth - 8.5"

AMS180



- Wall mount
- 14-gauge cold rolled steel body
- Barrel lock
- .220" thick clear polycarbonate window
- Includes Window Guard™ paint shield for vandal protection
- Off white powder coat finish
- Hinged lid for easy access
- **Dimensions:**
Housing Width - 5.5"
Housing Height - 8.25"
Housing Depth - 8.5"

ACEM20



- Wedge ceiling mount
- 14-gauge steel body
- 3/16" polycarbonate window
- Includes Window Guard™ paint shield for vandal protection
- Off white powder coat finish
- Easy installation and servicing
- **Dimensions:**
Housing Length - 8.37"
Housing Width - 5.44"
Housing Height - 4.67"

OW128

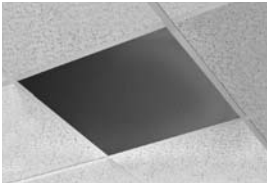

- Ceiling view window
- Replaces standard 2x2 ceiling tile
- Includes camera mounting bracket
- Tinted acrylic (1 Fstop light reduction)
- **Dimensions:**
Housing Width - 12"

MAXIMUM FIXED CAMERA/LENS LENGTHS

Model	One Camera
ACE20	8"
ACEM20	8.5"
ACN90	6"
AMS90	8"
AMS180	8"
BH8W	8"
CN90	9.5"
IPCH8	8"
RC200	11"

Options and Accessories

- FM2 fixed camera bracket for OW128
- OD1 metal dust cover for RC200
- KFL13 flashing light kit for IPCH8 and BH8W
- HTK24 24 VAC heater kit for IPCH8, BH8W, AMS90, AMS180, and ACEM20
- AMSWG Window Guard™ Paint Shield replacement pack for AMS90, AMS180, and ACEM20