

TWN4 PALON COMPACT LIGHT PANEL

RFID READER/WRITER SUPPORTING LF, HF AND NFC FOR PANEL MOUNT



TWN4 Palon Compact Light Panel is a versatile panel mount reader for integration into third-party products and devices. It supports enhanced interfaces, especially RS-485. The new compact Palon Panel inherits all advantages and integrated tool support of the ELATEC TWN4 family. The IP65 protected housing is easy to install.

TWN4 Palon Compact Light Panel is a multi-technology reader/writer family supporting almost all 125 kHz/134,2 kHz and 13,56 MHz contactless technologies, including NFC. On-board antennas for HF and LF allow excellent contactless performance.

Special features:

- + Optimized housing design for easy, fast and secure installation
- + Integrated LF and HF antennas
- + One onboard SAM socket (Secure Access Module)
- + Interfaces: RS-485, Wiegand or Clock/Data. OSDP protocol optionally, USB
- + Supports quick (re)configuration over network and over wireless interface with TWN4 CONFIG Card
- + Direct chip-commands support
- + Firmware update in the field possible
- + Powerful SDK for writing apps which are executed directly on the reader
- + Onboard 18 kB flash storage, e.g. for storing user accessible non-volatile data
- + TWN4 Upgrade Card for P and PI options available on request
- + 3D construction data (STEP) available on request



TECHNICAL DATA

FREQUENCY	125 kHz/134,2 kHz (LF) / 13,56 MHz (HF)
ANTENNAS	Integrated
HOUSING	Transparent Polycarbonate (PC) housing, black PC outer mounting ring. TWN4 Palon Panel PCB pre-installed. ABS locknut M63 x 1.5, black or grey, pre-installed design inlay (customizable). For mounting hole diameter 63,2 mm with anti-twist protection
DIMENSIONS (L X W X H)	82 mm x 82 mm x 34,2 mm (3,23 inch x 3,23 inch x 1,35 inch)
POWER SUPPLY	9.0 V - 30 V via connector X1; 4.3 V - 5.5 V via micro USB Limited power source according to IEC60950-1 or PS2 classified IEC62368-1, short-circuit current < 8 A
CURRENT CONSUMPTION	Operating: typ. 150 mA @12 V; Idle: typ. 50 mA @12 V; Peak typ. 230 mA @12 V
TEMPERATURE RANGE	Operating: -25 °C up to +80 °C (-13 °F up to +176 °F) Storage: -40 °C up to +85 °C (-40 °F up to +185 °F)
RELATIVE HUMIDITY	IP65 protected housing (frontside, when mounted) 5% to 95% non-condensing (inner electronic components)
READ- / WRITE DISTANCE	Up to 100 mm / 4 inch, depending on transponder and OEM environment
PERIPHERAL INTERFACES	RS-485; OSDP ⁸⁾ protocol optionally; Output 5V: Wiegand (D0/D1) or Clock/Data; USB
OPERATING MODES (USB)	USB keyboard emulation – USB virtual COM port – CCID / PC/SC 2.01
MTBF	500.000 hours (electronic components)
WEIGHT	77 g (2,72 oz)
WIRE CONNECTOR	PCB terminal block, 8 positions, push-in spring connection for wires 0.2 to 0.5 mm ² / AWG 24 to 20, tool-free cable wiring
SABOTAGE DETECTION	Infrared tamper detector, front facing
DIP SWITCH	8 position DIP switch for RS-485: addressing, speed settings, line termination
SIGNALING	Center RGB LED; acoustic loudspeaker
SUPPORTED TRANSPONDERS (STANDARD) 13,56 MHz	<u>ISO14443A:</u> LEGIC Advant ¹⁾ , MIFARE Classic, MIFARE Classic EV ¹²⁾ , MIFARE Mini, MIFARE DESFire EV1, MIFARE DESFire EV2 ²⁾ , MIFARE Plus S, X, MIFARE Pro X ³⁾ , MIFARE Ultralight, MIFARE Ultralight C, MIFARE Ultralight EV1, NTAG2xx, SLE44R35, SLE66Rxx (my-d move) ⁴⁾ , Topaz, HID iClass SEOS ¹⁾ <u>ISO14443B:</u> Calypso ³⁾ , Calypso Innovatron protocol ³⁾ , CEPAS ³⁾ , HID iCLASS ¹⁾ , Moneo ³⁾ , Pico Pass ⁴⁾ , SRI4K, SRIX4K, SRI512, SRT512 <u>ISO18092 ECMA-340:</u> NFC Forum Tag 1-5, NFC Peer-to-Peer, Sony FeliCa ⁵⁾ , NFC Active and passive communication mode <u>ISO15693:</u> EM4x33 ³⁾ , EM4x35 ³⁾ , HID iCLASS ¹⁾ , HID iCLASS SE/SR ¹⁾ , ICODE SLI, LEGIC Advant ¹⁾ , M24LR16/64, MB89R118/119, SRF55Vxx (my-d vicinity) ³⁾ , Tag-it, PicoPass ⁴⁾
SUPPORTED TRANSPONDERS (STANDARD) 125 kHz ¹²⁾ , 134,2 kHz ¹²⁾	AWID, Cardax, CASI-RUSCO, Deister ⁶⁾ , EM4100, 4102, 4200 ⁷⁾ , EM4050, 4150, 4450, 4550, EM4305 ⁸⁾ , FDX-B, EM4105, HITAG 1 ⁹⁾ , HITAG 2 ⁹⁾ , HITAG S ⁹⁾ , ICT ⁸⁾ , IDTECK, Isonas, Keri, Miro, Nedap ⁶⁾ , PAC, Pyramid, Q5, T5557, T5567, T5577, TIRIS/HDX, TITAN (EM4050), UNIQUE, ZODIAC
SUPPORTED TRANSPONDERS (OPTION P)	All standard transponders, Cotag, G-Prox ⁵⁾ , HID DuoProx II, HID ISO Prox II, HID Micro Prox, HID ProxKey III, HID Prox, HID Prox II, Indala, ioProx, Nexwatch

SUPPORTED TRANSPONDERS (OPTION PI)	Requires TWN4 SIO Card, All Standard Transponders, All Version P Transponders, HID iCLASS, HID iCLASS SE/SR/Elite, HID iCLASS SEOS (CSN & Facility Code/PAC) ¹⁰⁾ ,	
OS SUPPORT	Windows XP, Vista, Embedded CE ⁸⁾ , 7 (32-/64-bit), 8, 8.1, 10, Linux, Android ⁹⁾ , iOS ⁸⁾ , MAC OS X ⁸⁾	
TRANSMISSION SPEED	RS-485: up to 38.400 baud; USB Full speed (12 Mbit/s); HF Air: up to 848 kbit/s,	
EXTENSION SLOT	One SAM socket for ID-000 cards or modules	
CERTIFICATION NAME	TWN4 Palon Compact	
CERTIFICATION(S)	CE, RoHS-II compliant – pending FCC / IC	
ORDER CODE(S)	Box Kit: TWN4 Palon Compact Panel Light reader in transparent housing, black outer mounting ring, locknut, O ring seal, standard inlay, installation instruction, cardboard box	
	T4PK-F02TR6	TWN4 Palon Compact, Light Panel Kit, as described
	T4PK-F02TR6-P	same, P Option
	T4PK-F02TR6-PI	same, PI Option
ACCESSORIES	Bulk Packaging: TWN4 Palon Compact Panel Light reader in transparent housing, black outer mounting ring, locknut, O ring seal, standard inlay, packed in bulk plastic bag	
	T4PK-F04TR6	TWN4 Palon Compact, Light Panel Kit, as described
	T4PK-F04TR6-P	same, P Option
	T4PK-F04TR6-PI	same, PI Option
ACCESSORIES	HOPL-YR01TR	Palon Panel transparent housing with black design frame
	MECH-LNB01	Locknut
	MECH-ORB01	O-ring seal
	CAB-B9	USB A / USB Micro Cable

¹⁾UID only ²⁾r/w enhanced security features on request ³⁾r/w in direct chip command mode ⁴⁾UID only, read/write on request ⁵⁾UID + r/w public area ⁶⁾Hash value only

⁷⁾Only emulation of 4100, 4102 ⁸⁾On request ⁹⁾Without encryption ¹⁰⁾UID + PAC (CSN & Facility Code), r/w on request ¹¹⁾In preparation

¹²⁾ 125/134.2kHz technology requires a Russian local test and import license from the ministry of Trade and Industry (MINPROMTORC). This license has to be in place before Elatec can accept any order to be shipped to Russia

DRAWING / CONNECTOR ASSIGNMENT

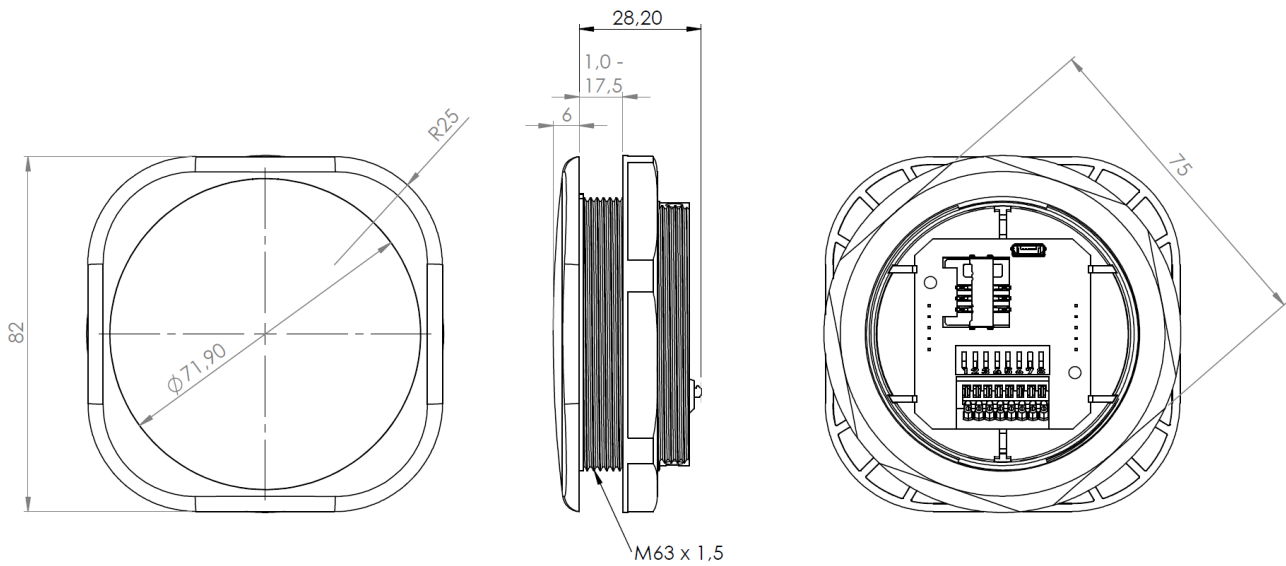

(All measures in mm)

DIP	ASSIGNMENT
1	RS-485 address 0 LSB
2	RS-485 address 1
3	RS-485 address 2
4	RS-485 address 3 MSB
5	RS-485 BIAS on/off
6	RS-485 speed 0
7	RS-485 speed 1
8	RS-485 termination 120 Ohm on/off

PIN	ASSIGNMENT
1	(unused)
2	(unused)
3	RS-485 A
4	RS-485 B
5	TTL Wiegand D0 or DATA
6	TTL Wiegand D1 or CLOCK
7	VIN 9 – 30 Volt
8	GND

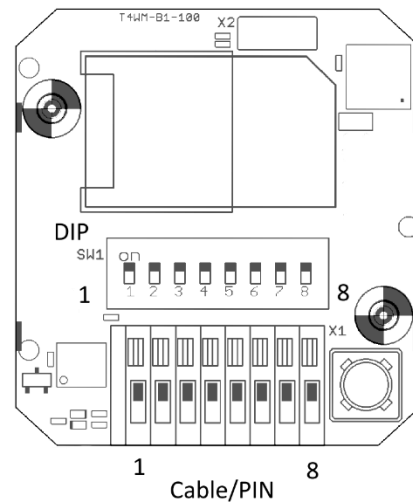

Drawing / rear view PCB

Firmware may change the assignment of the DIP switch. Please refer to the TWN4 Palon manual.
For Wiegand, Clock/Data the DIP switch is not used.

ELATEC GmbH
 Zeppelinstr. 1
 82178 Puchheim • Germany
 P +49 89 552 9961 0 • F +49 89 552 9961 129
 E-Mail: info-rfid@elatec.com

ELATEC USA Inc.
 4203 SW High Meadows Ave
 Palm City • FL 34990 • USA
 P +1 772 210 2263 • F +1 772 382 3749
 E-Mail: americas-info@elatec.com

ELATEC Technology (Shenzhen) LLC
 No. 716 Industrial Bank Tower
 Futian District • Shenzhen • China
 P/F +86 755 2394 6014
 E-Mail: apac-info@elatec.com

ELATEC reserves the right to change any information or data in this document without prior notice. ELATEC declines all responsibility for the use of this product with any other specification but the one mentioned above. Any additional requirement for a specific customer application has to be validated by the customer himself at his own responsibility. Where application information is given, it is only advisory and does not form part of the specification. Disclaimer: All names used in this document are registered trademarks of their respective owners.