

S133

Bench Scale



- **Display** – 52 mm / 2" high, 7 segment LCD display with LED annunciator and configurable backlight
- **Keyboard** – Seven simple to use, large keys
- **Robust Base** – 520 mm x 420 mm / 20.5" x 16.5" die cast aluminium base with stainless steel shroud
- **Totalizing Functionality** – Allows the number of weighings and the total amount of weight to be stored and recalled
- **Power** – Powered by either the internal rechargeable battery or via the external power adapter
- **RS-232 Option**
- **Checkweighing Mode** – Configurable audible alarm for targets and three visual LED annunciators for under, over, or accept
- **OIML Approved** – 3000 division approved; 6000 divisions unapproved

S133 Bench Scale

Specifications

Capacities:

- 60 kg x 0.01 kg (unapproved)
- 150 kg x 0.02 kg (unapproved)
- 300 kg x 0.05 kg (unapproved)

- 60 kg x 0.02 kg (approved)
- 150 kg x 0.05 kg (approved)
- 300 kg x 0.1 kg (approved)

Tare: 100% subtractive

Display: 5 1/2 digit 7 segment LCD with configurable backlight and icons for gross, net, tare, zero, kg, stable, low battery

Construction: Die cast base, ABS plastic indicator, 520 mm x 420 mm / 20.5" x 16.5" stainless steel platter and 660 mm / 26" column. Four adjustable feet and level indicator at base of pole to ensure maximum stability

Adjustable Indicator: Mounted to a stainless steel column that can be tilted throughout approximately 150° range for easy visibility

LED Annunciators: Over; Under; Accept

Key Functions: Gross/Net; Print; Memory Recall; Accumulate; Tare; Zero; Power On/Off

Check Weighing: Simple check weighing feature with built in annunciators for target setting and configurable audio alarm

Product Code:

- 816965004652: 60 kg (unapproved)
- 816965004669: 150 kg (unapproved)
- 816965004676: 300 kg (unapproved)

- AWT05-504543 (approved)
- AWT05-504544 (approved)
- AWT05-504545 (approved)

RS-232 Kit Option:

AWT25-800002

Weight Accumulation and Totalizer: Allows the number of weighings and the total amount of weight to be stored and recalled

Power Adapter: 120/220VAC @ 60/50 HZ, 9 VDC, 800mA, CE approved external power adapters

Internal Rechargeable Battery: 6 VDC rechargeable battery. 12 hours to fully charge the scale. Approximately 20 hours of continuous battery life

Operating Temperature:
-10° C to 40° C / 14° F to 104° F

Operating Humidity: 0 to 85% RH (non-condensing)

EC Type Approval Certificate Number: UK2863

OIML Certificate Number: R76/1992-GB1-09.08

Shipping Specifications:

- Net – 13.5 kg / 29.8 lb
- Gross – 16.4 kg / 36.2 lb

Package Dimension:

820 mm x 590 mm x 250 mm / 32.3" x 23.2" x 9.8"

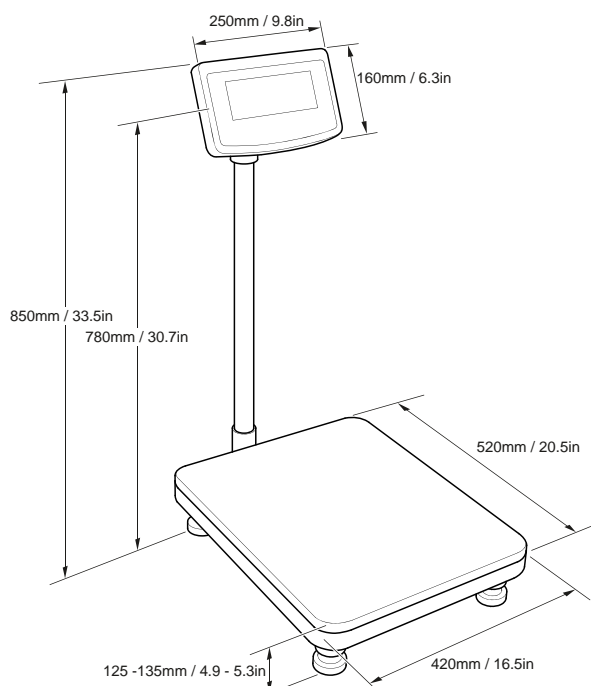

a division of Avery Weigh-Tronix, LLC

Brecknell

1000 Armstrong Dr., Fairmont, MN 56031
Toll free: 800-637-0529, Tel: 507-238-8702
Fax: 507-238-8271
e-mail: sales@brecknellscales.com
www.brecknellscales.com



Brecknell

Foundry Lane, Smethwick
West Midlands B66 2LP UK
Tel: +44 (0) 845 246 6717
Fax: +44 (0) 845 246 6718
Email: sales@brecknellscales.co.uk
www.brecknellscales.co.uk

